

StarFire-V60/180 is based on a device of Altera® Stratix II 60 (or 180) that is equivalent to up to 600K (or 1.8M) AISC gates to be prototyped. With highly flexible power, clock, memory and peripheral configurations, StarFire-V60/180 enables users to shorten the time to market greatly on their projects.

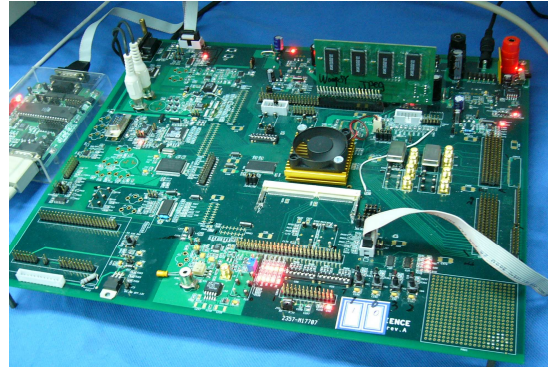

StarFire-V180 working

StarFire-V60/180 prototype board supports SOC/ASIC and IP design verification on Digital TV, STB, PMP, mobile multimedia, and any other Video/Audio related designs.

● KEY FEATURES

1. Clock Management:
8 oscillators on board at 3.3V or 5V, 8 external clock interfaces
2. User and Extension I/O:
Total 280 I/O ports; Voltage Groups of I/O and ref Voltage are adjustable and configurable to differential standard or single end
3. Memory:
 - A) 133MHz SDRAM SODIMM
 - B) 128Mb DDR SDRAM on board
 - C) 128Mb SDRAM on board
 - D) SRAM or FLASH is selectable
4. Video Input:
RGB and VGA input, three-channel transfer at 8 bit 140 MSPS, up to SXVGA (1280x1024@75Hz) video resolution, 300MHz analog bandwidth, SNR 43dB
5. Baseband IQ interface: double channel 6 bit ADC, both single and differential
6. ADC: High performance ADC at 80MHz, 10 bit, 2Vp-p input voltage
7. DAC: three standalone channels of high speed DAC at 240MSPS, 10bit
8. 2 audio outputs, I2S and PCM
9. TV decoder:
VPC3230D at 54MHz, with 8/16bit output
10. TS output:
QPSK/QAM output at 0 Intermediate Frequency, DVB Standard TS output
11. 10 LEDs, 4 buttons, 6 tri-state switches
12. 2 RS232 interfaces, 2 I2C interfaces
13. FPGA download:
ByteBlaster support, or through EPC64 device on board, off/in line

● **Diagram of system:**

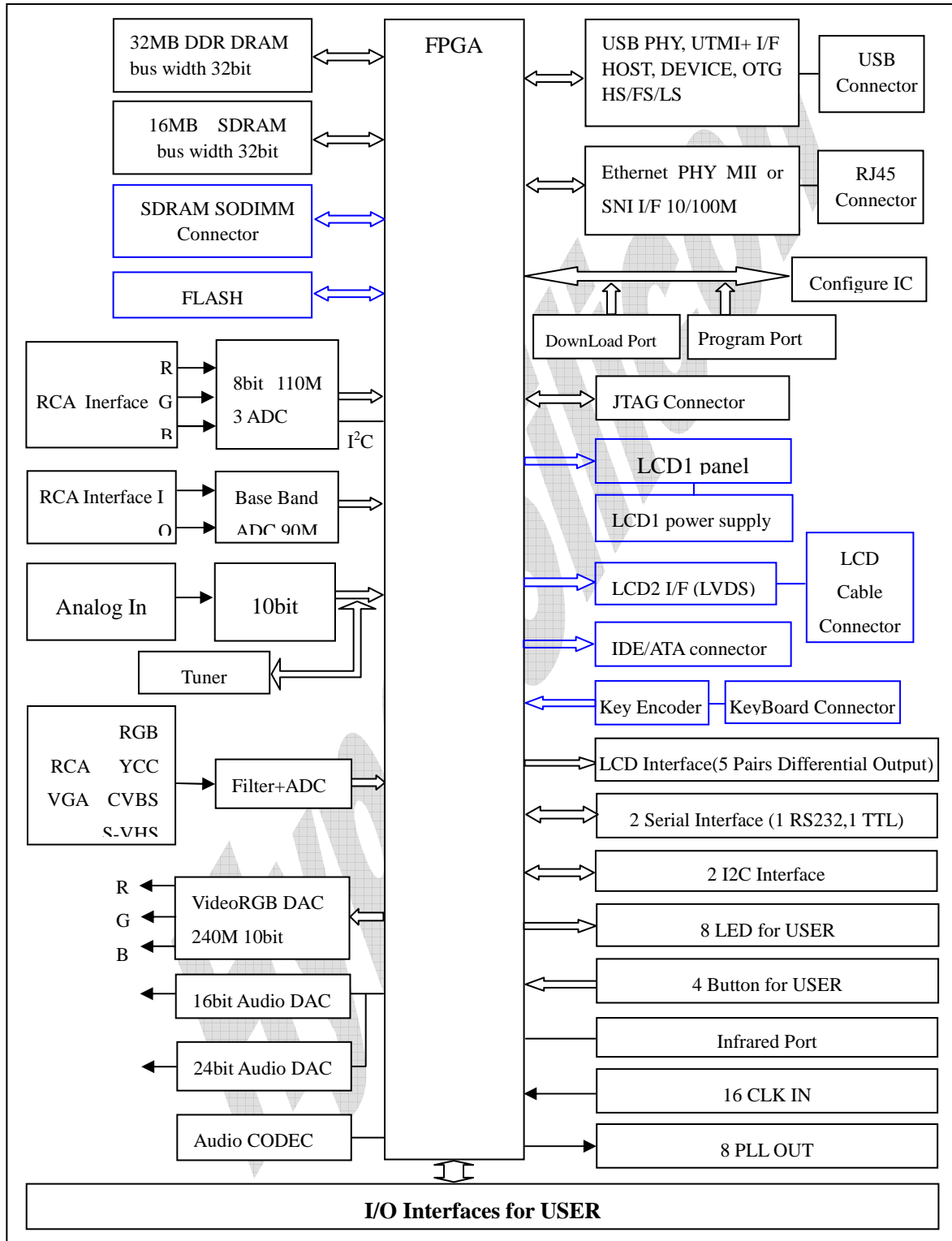

* Blue Parts are for Optional

Notes: Based on the standard configuration, any customizing design is welcomed

Copyright reserved. HY-FPGA Version 1.0, August 2005.